

[FLOOR EQUIPMENT PARTS.COM](http://FLOOR EQUIPMENT PARTS.COM)

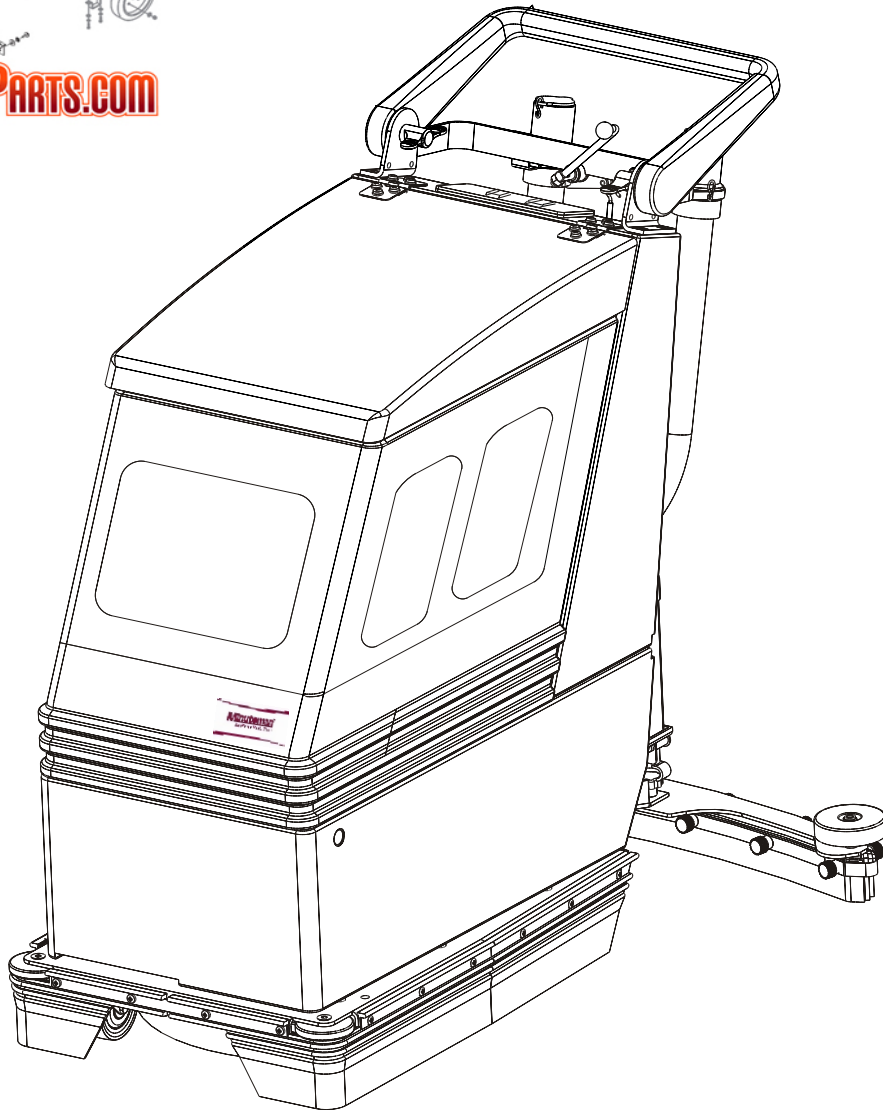

## Technical Specifications

<b>Model</b>	<b>E 17e</b>
<b>Model No</b>	<b>M 17115</b>
Length with squeegee	1000 mm
Width without/with Squeegee	450/750 mm
Height	807/870 mm
Brush Head	430 mm
Squeegee	750 mm
Theoretical Performance	1700 m <sup>2</sup> /h
Driving Speed	Upto 4 km/h
Main wheel,dia/width	75/28 mm
Rear wheel,dia/width	150/30 mm
Volume of Fresh water tank	22 lts
Volume of soiled water tank	22 lts
Pump throughput, max	1.7 lts
Dead weight of machine	184 LBS
Total weight, ready to operate,wet	241.4 LBS
No of Brushes	1
Brush Dia	17 inches
Brush Speed	260 rpm
Brush contact pressure,max upto	48.5 LBS
Vacuum-Air throughput	43 L/Sec
Vacuum pressure	1630 mm of H <sub>2</sub> O
Service Voltage	115 V/AC
Frequency	60 Hz
Nominal power,total,max	1800 W
Circuit Breaker for brush motor	12 A
Circuit Breaker for suction turbine	10 A
Brush Motor (Rated)	800 W
Vacuum Motor (Rated)	900 W
Noise Level	75 db(A)

## For Safety When Servicing or Maintaining Machine

- Disconnect the power to the machine.
- Avoid moving parts. Do not wear loose jackets, shirts or sleeves when working on machine.
- Do not clean machine with pressure washer.
- Authorized personnel must perform repairs and maintenance. Use Minuteman supplied

**Table of Contents**

<b>Technical Specifications</b> .....	<b>2</b>
<b>Safety Instructions</b> .....	<b>2</b>
Chassis.....	4
Brush Drive Group.....	6
Brush Lifting System.....	8
Vacuum Motor Covering.....	10
Tank.....	12
Lifting of Squeegee.....	14
Squeegee.....	16
Electrical Equipment.....	18
Electric.....	20
<b>Minuteman Limited Warranty</b> .....	<b>22</b>

Chassis

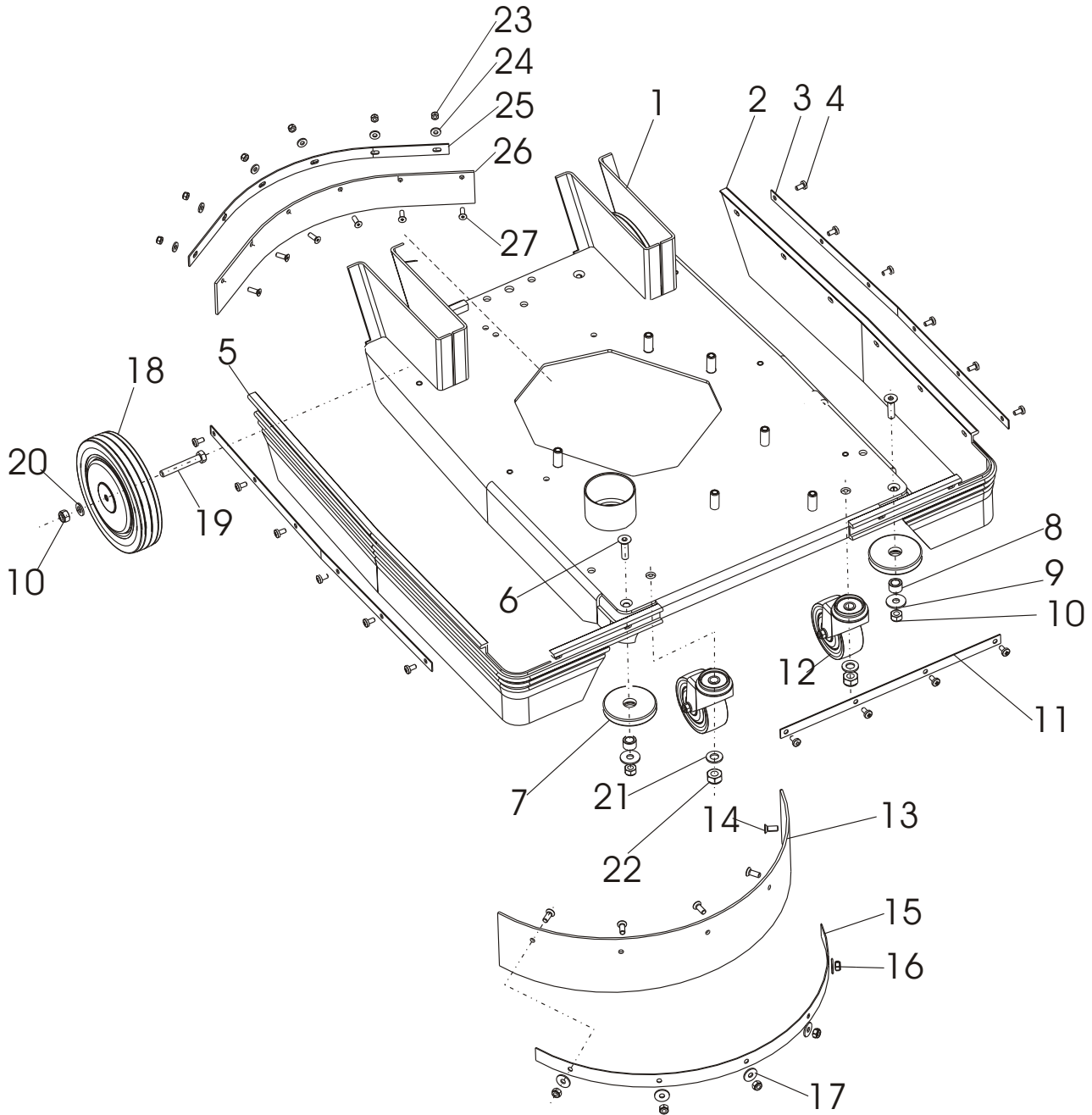

<b>E17e CHASSIS</b>				
<b>SL. NO.</b>	<b>PART NO.</b>	<b>DESCRIPTION</b>	<b>SIZE</b>	<b>QTY</b>
1	3280027	Base Plate Assy- E17		1
2	922081	Spray Protector-Left		1
3	922082	Rail Bar		2
4	817203	Screw	M5x10	16
5	922080	Spray Protector-Right		1
6	829409	CSK Allen Bolt	M8x30	2
7	922078	Deflector Roller		2
8	922077	Bush-Deflector Roller		2
9	844082	Washer	8.4x24x2	2
10	859086	Nylock Nut	M8	4
11	922083	Rail Bar		1
12	927837	Castor Wheel (Set)		2
13	922079	Sealing Tape		1
14	812306	Screw	M6x16	5
15	922086	Strip		1
16	859066	Nylock Nut	M6	5
17	844061	Washer	6.4x12x1.6	5
18	927836	Main Wheel		2
19	804414	Hex Bolt	M8x55	2
20	844081	Washer	8.4X16X1.6	2
21	932046	Spacer		2
22	859106	Nylock Nut	M10	2
23	859056	Nylock Nut	M5	6
24	844051	Washer	5.2x10x1.6	6
25	927088	Clamp-strip		1
26	927811	Splash guard		1
27	812206	Screw	M5X16	6

Brush Drive Group

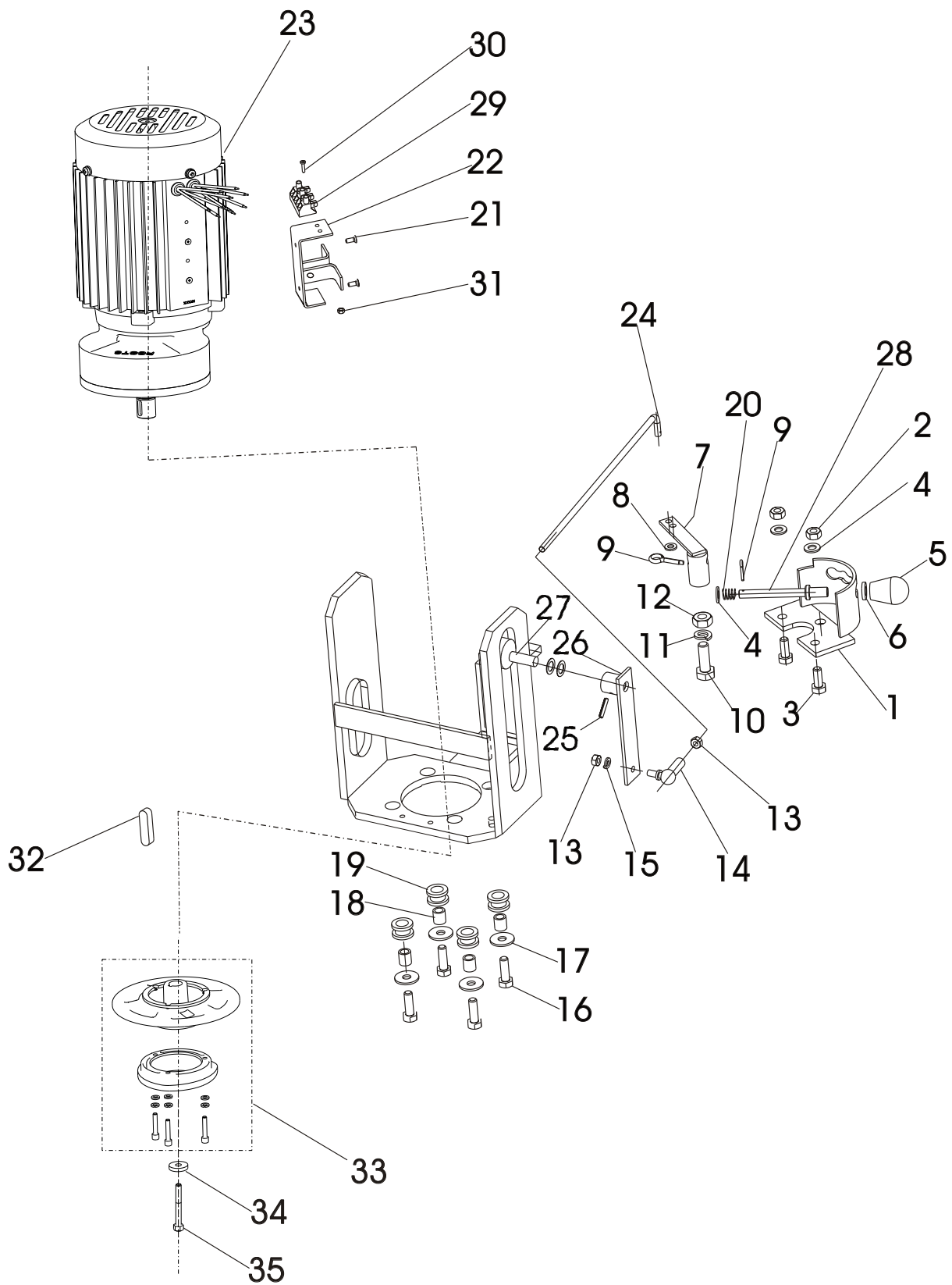

<b>E17e BRUSH DRIVE GROUP</b>				
<b>SL. NO.</b>	<b>PART NO.</b>	<b>DESCRIPTION</b>	<b>SIZE</b>	<b>QTY</b>
1	922833	Speed Lever Support		1
2	822088	Hex Nut	M8	2
3	802407	Hex Bolt	M8X20	2
4	844081	Washer	8.4x16x1.6	3
5	927047	Speed Control Handle		1
6	927063	Washer		1
7	922834	Arm		1
8	844061	Washer	6.4x12x1.6	1
9	842608	Cotter Pin	2x16	2
10	802509	Hex Bolt	M10X30	1
11	863100	Spring Washer	M10	1
12	833108	Hex Lock Nut	M10	1
13	822068	Hex Nut	M6	2
14	922463	Angle Joint		1
15	863060	Spring Washer	M6	4
16	802408	Hex Bolt	M8x25	4
17	844082	Washer	8.4x24x2	4
18	922130	Sleeve		4
19	922031	Grommet		4
20	922123	Spring		1
21	817101	Screw	M4x6	2
22	927876	Clamp-Capacitor		1
23	3280031	Geared Motor with Connector- E17 (115V 60Hz)		1
24	922124	Lifting Rod		1
25	856107	Dowel Pin	4x20	1
26	922832	Lever		1
27	922831	Disc Pin		1
28	927082	Threaded Rod		1
29	925117	Terminal strip		1
30	817108	Screw	M4x25	1
31	822048	Nut	M4	1
32	922153	Key		1
33	3580110	Catch Assy		1
34	922126	Washer	9.0x28.0x6.0	1
35	802408	Hex head screw	M8x25	1

Brush Lifting System

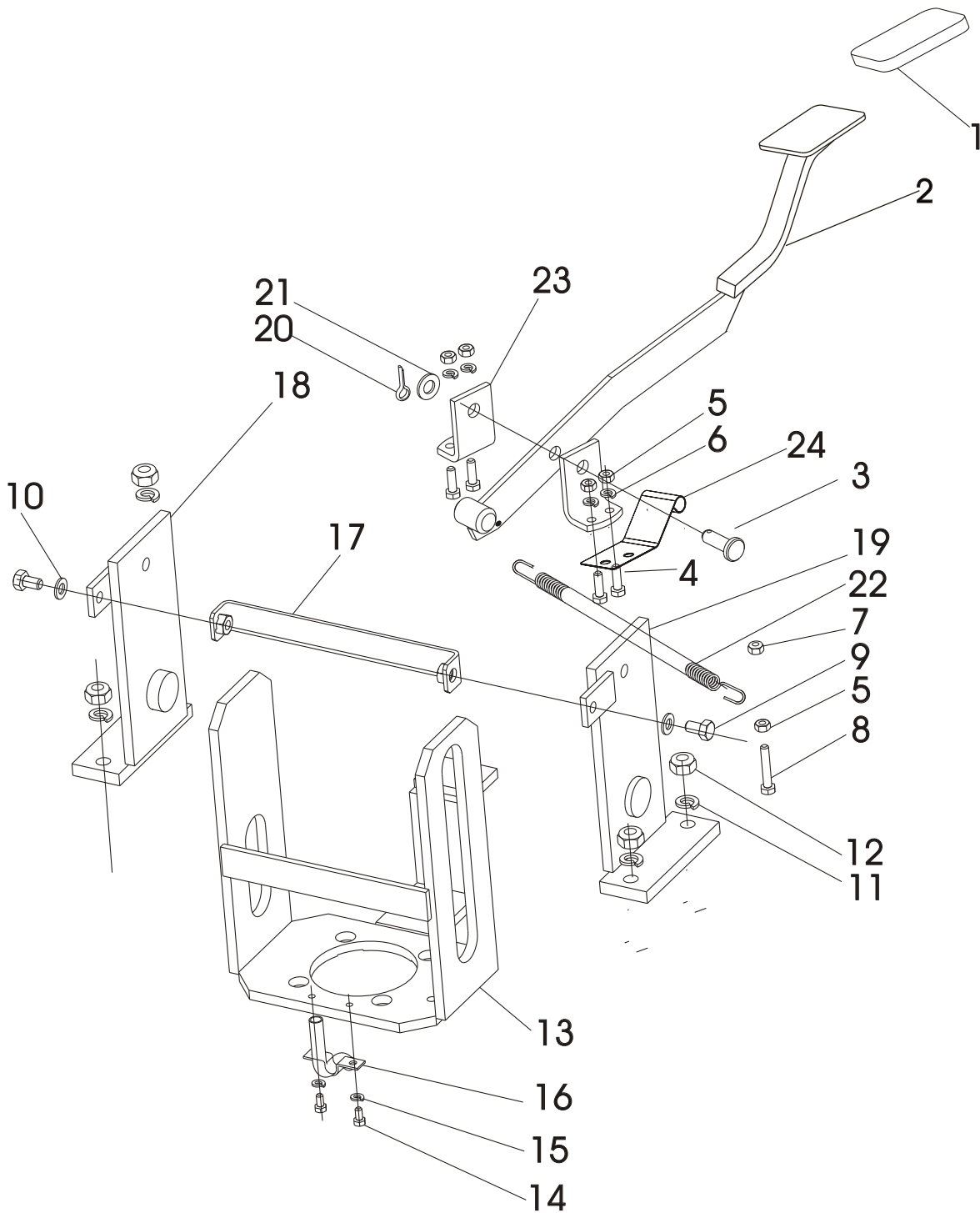



<b>E17e BRUSH LIFTING SYSTEM</b>				
<b>SL. NO.</b>	<b>PART NO.</b>	<b>DESCRIPTION</b>	<b>SIZE</b>	<b>QTY</b>
1	922353	Shoe		1
2	3280034	Pedal assy-E17		1
3	922187	Clevis pin		1
4	802307	Screw	M6x20	4
5	822068	Hex Nut	M6	5
6	863060	Spring Washer	M6	4
7	859066	Nylock Nut	M6	1
8	802310	Screw	M6x35	1
9	802407	Hex Bolt	M8x20	2
10	844081	Washer	8.4x16x1.6	2
11	863100	Spring Washer	M10	4
12	822108	Hex Nut	M10	4
13	3280033	Holder assy-Brush Motor-E17		1
14	802203	Screw	M5X10	2
15	863050	Spring Washer	M5	2
16	3280035	Bow Pipe assy-E17		1
17	932769	U Bracket-tie		1
18	927881	Stand-RH		1
19	927882	Stand-LH		1
20	842808	Cotter Pin	3.2x16	1
21	844101	Washer	10.5x20x2	1
22	922185	Spring		1
23	927194	L-Angle		2
24	932066	Spring -pedal		1

Vacuum Motor Covering

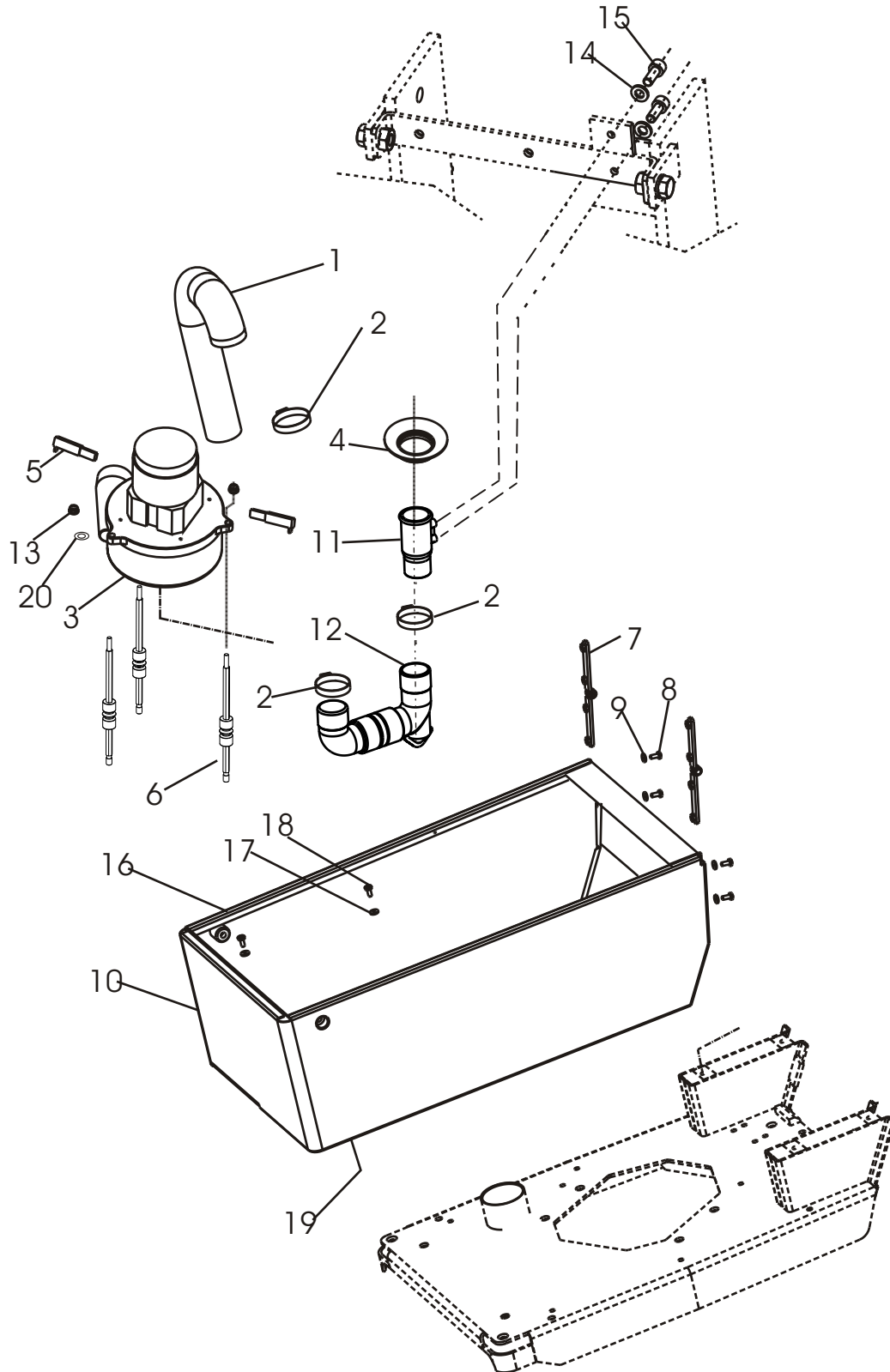

<b>E17e VACUUM MOTOR COVERING</b>				
<b>SL. NO.</b>	<b>PART NO.</b>	<b>DESCRIPTION</b>	<b>SIZE</b>	<b>QTY</b>
1	932780	Silencer Hose		1
2	881003	Hose Clamp	32-50	2
3	3280048	Vaccum Motor Assy-115V-60Hz		1
4	922366	Seal		1
5	3530368	Carbon Brush		2
6	932002	Stud vacuum motor		3
7	927756	Hinge		2
8	817204	Screw	M5x12	4
9	844051	Washer	5.3x10x1	4
10	927883	Bottom Frame		1
11	932004	Hose connector		1
12	932846	Suction hose		1
13	859066	Hex. Nut	M6	3
14	844051	Washer	M5	2
15	831204	Allen Screw	M5x12	2
16	927140	Gasket Frame		1
17	863050	Spring Washer	M5	6
18	831204	Allen Screw	M5x12	6
19	923255	Gasket Frame	1000x10x4	2
20	844061	Washer	M6	6

Tank

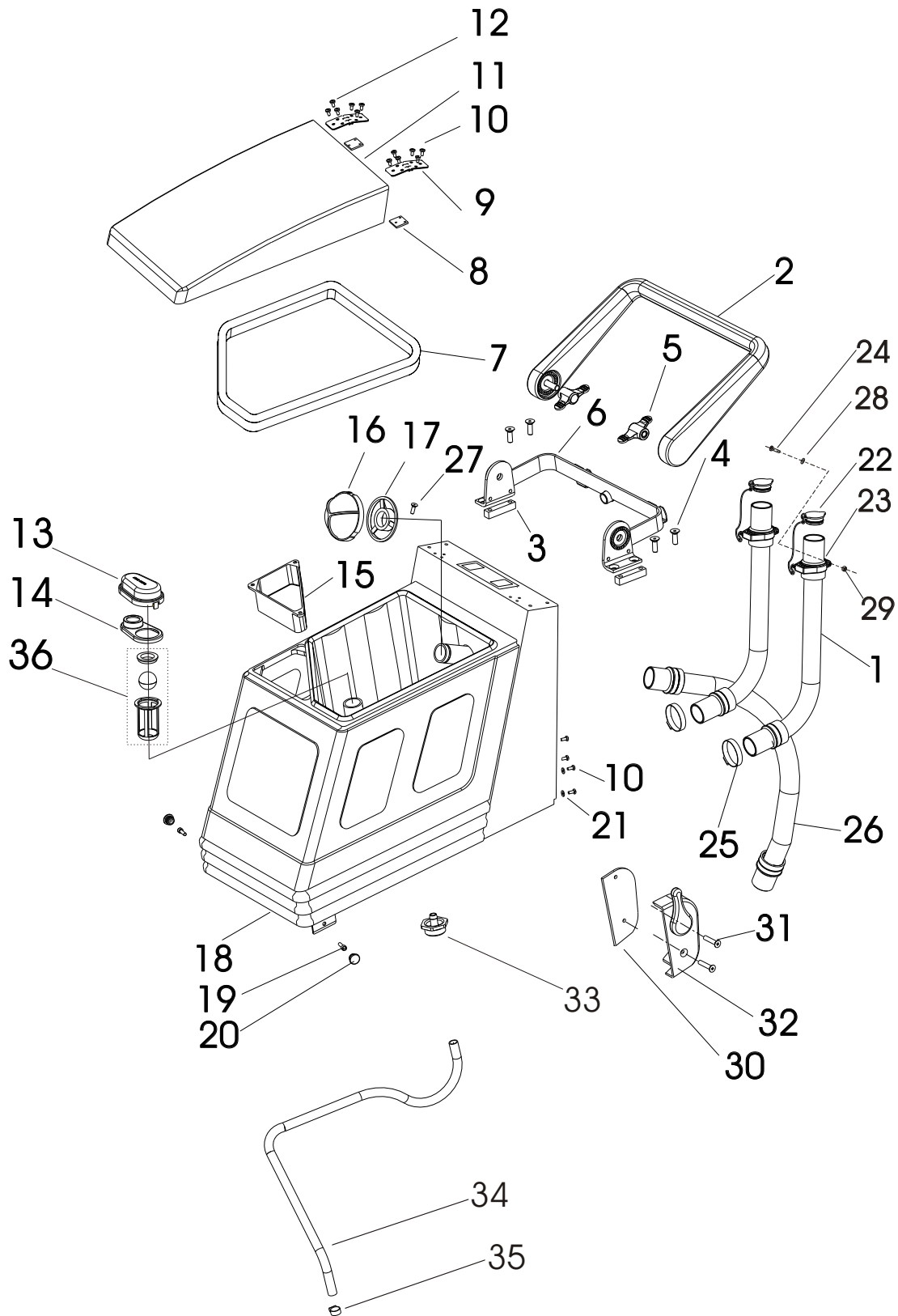

<b>E17e TANK</b>				
<b>SL. NO.</b>	<b>PART NO.</b>	<b>DESCRIPTION</b>	<b>SIZE</b>	<b>QTY</b>
1	927752	Drain hose		2
2	922828	Handle assy		1
3	922029	Threaded bar		2
4	829307	CSK Allen Screw	M6x20	4
5	927872	Knob-handle		2
6	927868	Bracket handle assy		1
7	3230002	Gasket Top Cover		1
8	927192	Bottom Plate		2
9	922819	Hinge		2
10	817204	Screw	M5x12	10
11	3280037	Top Cover assy -E17		1
12	817208	Screw Steel	M5x25	6
13	3230086	Float Top Housing		1
14	3230084	Float Bottom Housing		1
15	3230007	Strainer assy		1
16	3230010	Flow diverter		1
17	3230009	Flow diverter support		1
18	3280039	Tank and Rear Frame-E17		1
19	831307	Allen Screw	M6x20	2
20	927057	Cap		2
21	844051	Washer	5.3x10x1	4
22	922888	Cap With Chain Assy		2
23	932169	Clamp-drain hose		2
24	831207	Hexagonal socket head screw	M5x20	2
25	881028	Hose Clamp	32-45	2
26	922774	Squeegee hose		1
27	836004	CRPH Self Tapping Screw SS 304	M3.5x13	2
28	845052	Washer	5.2x10x1.6	2
29	859056	Nylock nut	M5	2
30	927134	Support Plate		1
31	812119	Screw	M4x30	2
32	927820	Valve		1
33	3230008	Connector tube		1
34	927136	Tube		1
35	881029	Hose Clamp	9.5~12	1
36	3280062	Float Assy EB430		1

Lifting for Squeegee

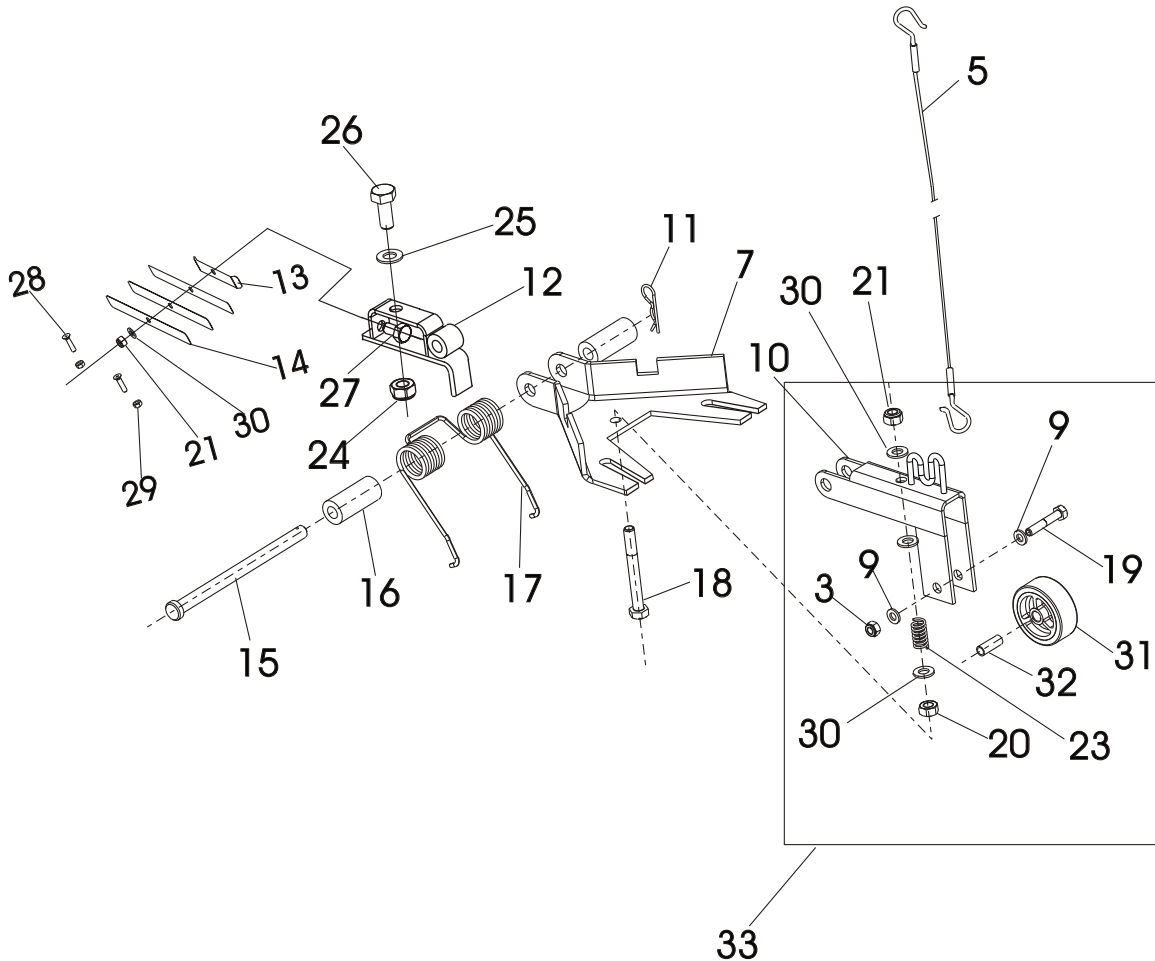
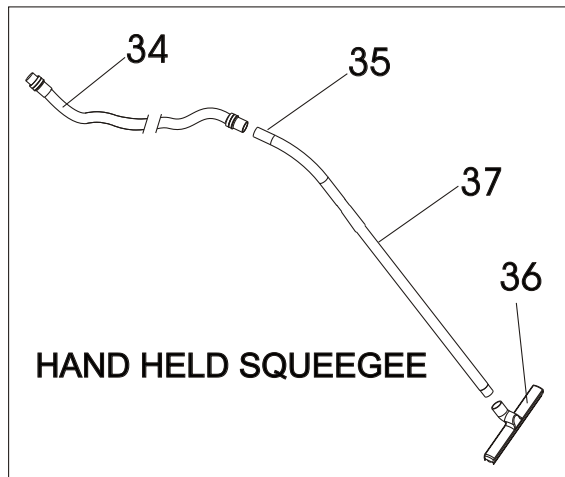
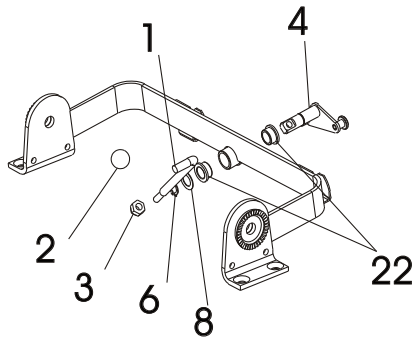

<b>E17e LIFTING FOR SQUEEGEE</b>				
<b>SL. NO.</b>	<b>PART NO.</b>	<b>DESCRIPTION</b>	<b>SIZE</b>	<b>QTY</b>
1	923119	Lever		1
2	923098	Knob		1
3	859066	Nylock Nut	M6	2
4	927757	Cam		1
5	927889	Rope		1
6	923418	Circlip	A12	1
7	3230076	Plate-Squeegee		1
8	923405	Washer	20x12.4x0.5	1
9	844061	Washer	6.4x12x1.6	2
10	927867	Bracket wheel assy		1
11	922164	Linch Pin		1
12	927887	Holder		1
13	922370	Leaf Spring		1
14	922369	Leaf Spring-Squeegee		3
15	927182	Stud		1
16	927183	Bush -stud		2
17	927184	Spring -parabolic squeegee		1
18	804414	Hex head screw	M8X55	1
19	804311	Hex head screw	M6X40	1
20	822088	Hex nut	M8	1
21	859086	Nylock Nut	M8	2
22	925108	Bush		2
23	927181	Spring -wheel bracket		1
24	859106	Nylock Nut	M10	1
25	844101	Washer	10.5x20x2	1
26	802508	Hex Bolt	M10x25	1
27	802406	Hex Bolt	M8x16	1
28	812308	Screw	M6x25	2
29	822068	Hex Nut	M6	2
30	844081	Washer	8.4x16x1.6	4
31	927873	Castor wheel -parabolic squeegee		1
32	927177	Sleeve -castor wheel parabolic squeegee		1
33	927891	Bracket -wheel group		1
		<b>OPTIONAL HAND HELD SQUEEGEE</b>		1
34	922898	Hose		1
35	922208	Pipe-handle		1
36	922207	Nozzle		1
37	922206	Pipe-Extension		1

Squeegee

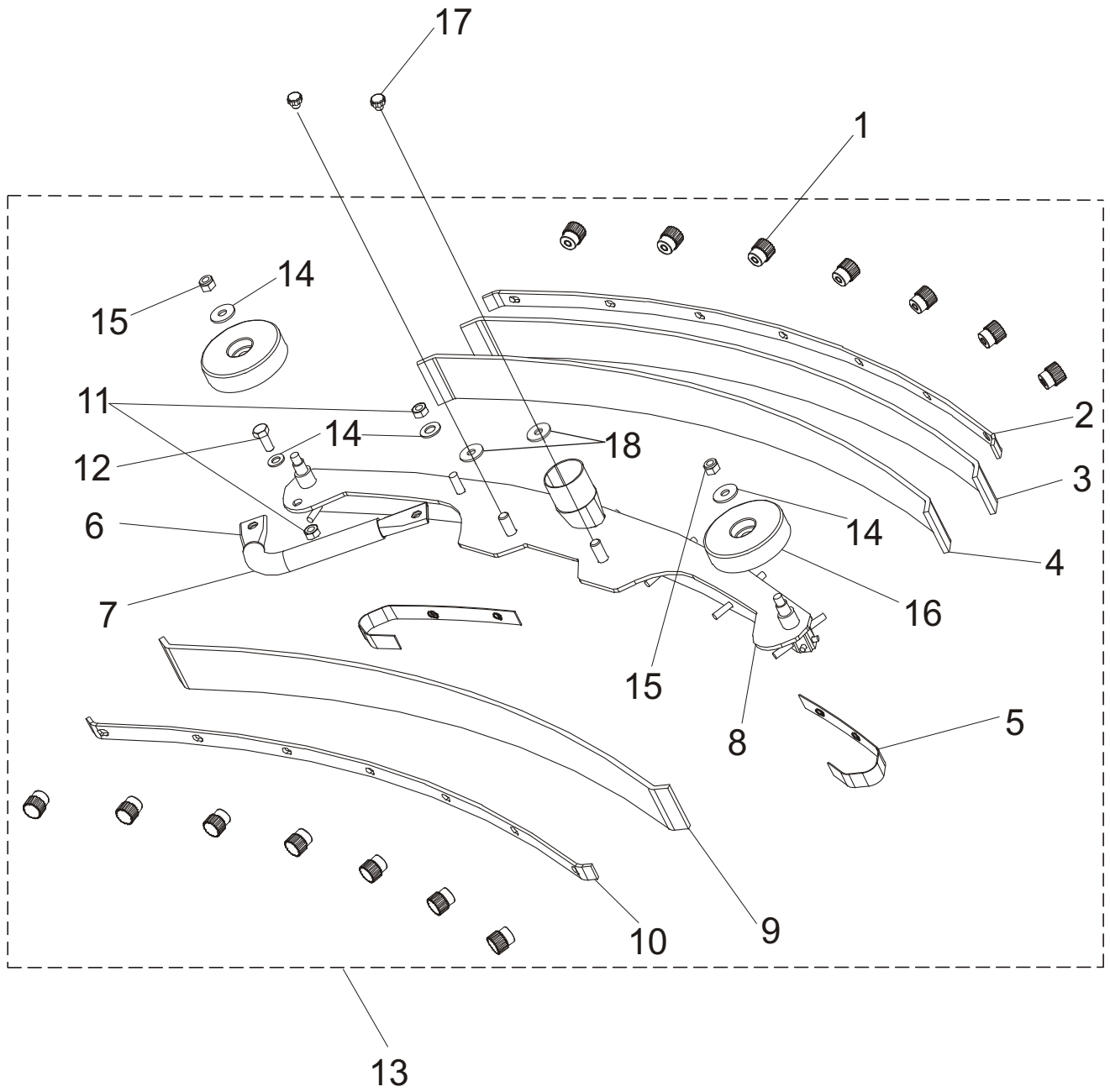



<b>E17e SQUEEGEE</b>				
<b>SL. NO.</b>	<b>PART NO.</b>	<b>DESCRIPTION</b>	<b>SIZE</b>	<b>QTY</b>
1	927871	Knob -lip		14
2	927189	Clamping strip -outer		1
3	927186	Squeegee lip - support		1
4	927161	Squeegee lip - outer		1
5	927174	End clamp		2
6	927176	Pipe-protection		1
7	927175	Hose pipe-protection		1
8	927854	Channel squeegee assy		1
9	927185	Squeegee lip -inner		1
10	927190	Clamping strip -inner		1
11	822088	Hex nut	M8	2
12	802406	Hex bolt	M8x16	1
13	927874	Parabolic squeegee		1
14	844081	Washer	8.4x16x1.6	4
15	859086	Nyloc Nut	M8	2
16	927159	Deflector roller		2
17	922279	Squeegee knob		2
18	844101	Washer	10.5x20x2	2

Electrical Equipment

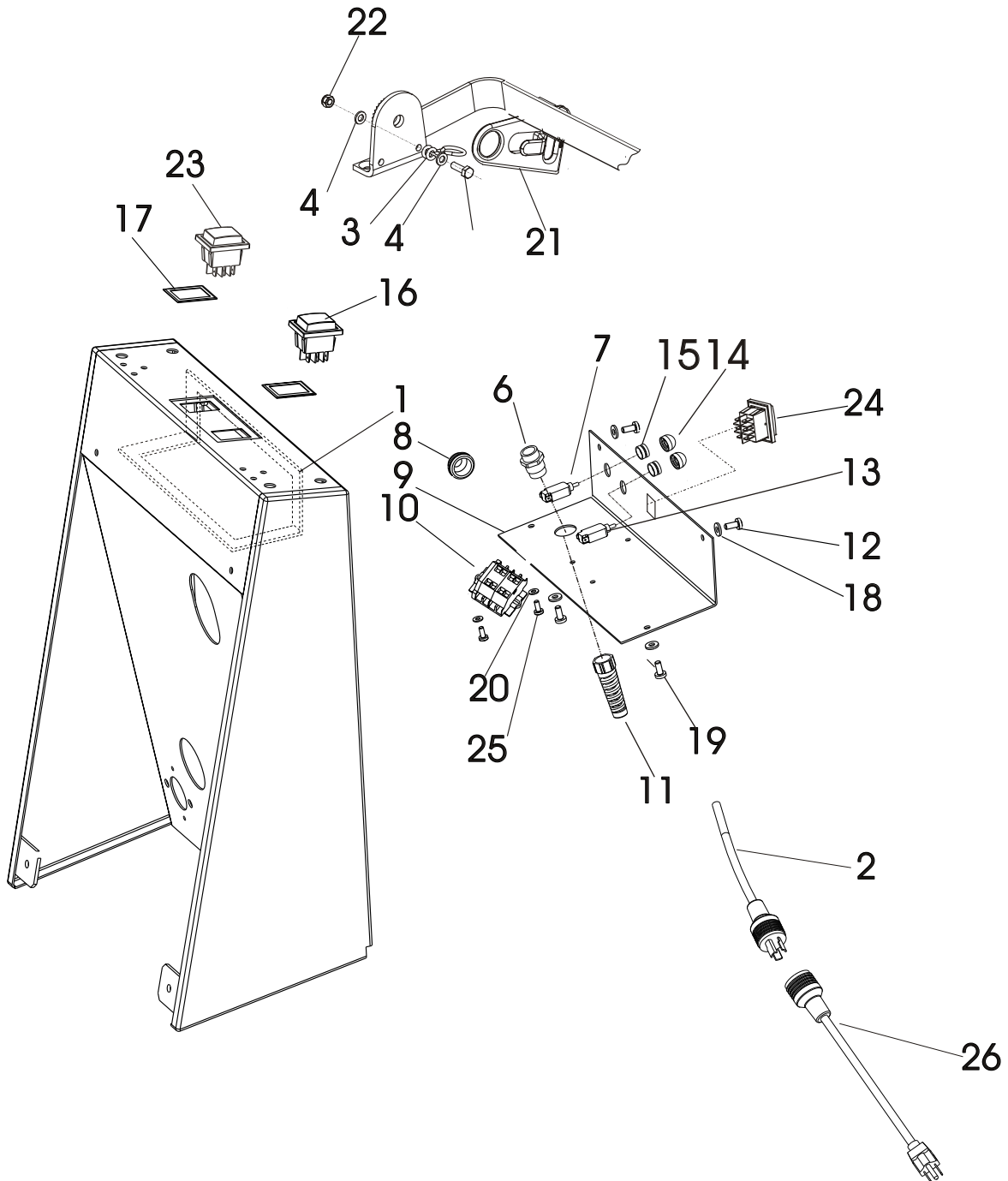

<b>E17e ELECTRICAL EQUIPMENT</b>				
<b>SL. NO.</b>	<b>PART NO.</b>	<b>DESCRIPTION</b>	<b>SIZE</b>	<b>QTY</b>
1	923255	Gasket	1000x10x4	1
2	3280063	Cord Pigtail 14/3 STW Pantone 430		1
3	922290	Clamp		1
4	844061	Washer	6.4x12x1.6	2
5	802307	Screw	M6x20	1
6	931165	Nut Cable Gland		1
7	925173	Circuit Breaker 10A	10A	1
8	932085	Seal		1
9	3230072	Panel Angle		1
10	3280036	Mains Connector-E17		1
11	872004	Cable Gland With Spiral BS Gland		1
12	817203	Screw	M5x10	4
13	847002	Circuit Breaker 12A	12A	1
14	925124	Cap		1
15	928107	Nut Circuit Breaker		2
16	3530072	Rocker Switch-vm		1
17	927052	Gasket		2
18	844051	Washer	5.3x10x1	4
19	817103	Screw	M4x10	2
20	844041	Washer	4.3x9x0.8	4
21	3280045	Cable Retainer		1
22	859066	Nylock Nut	M6	1
23	3530072	Rocker switch ( Brush motor)		1
24	3530073	Rocker switch ( Brush release)		1
25	817004	Screw	M3x12	2
26	3580233	Cord 14/3 STW 50 feet Pantone 430	50 feet	1

Electric

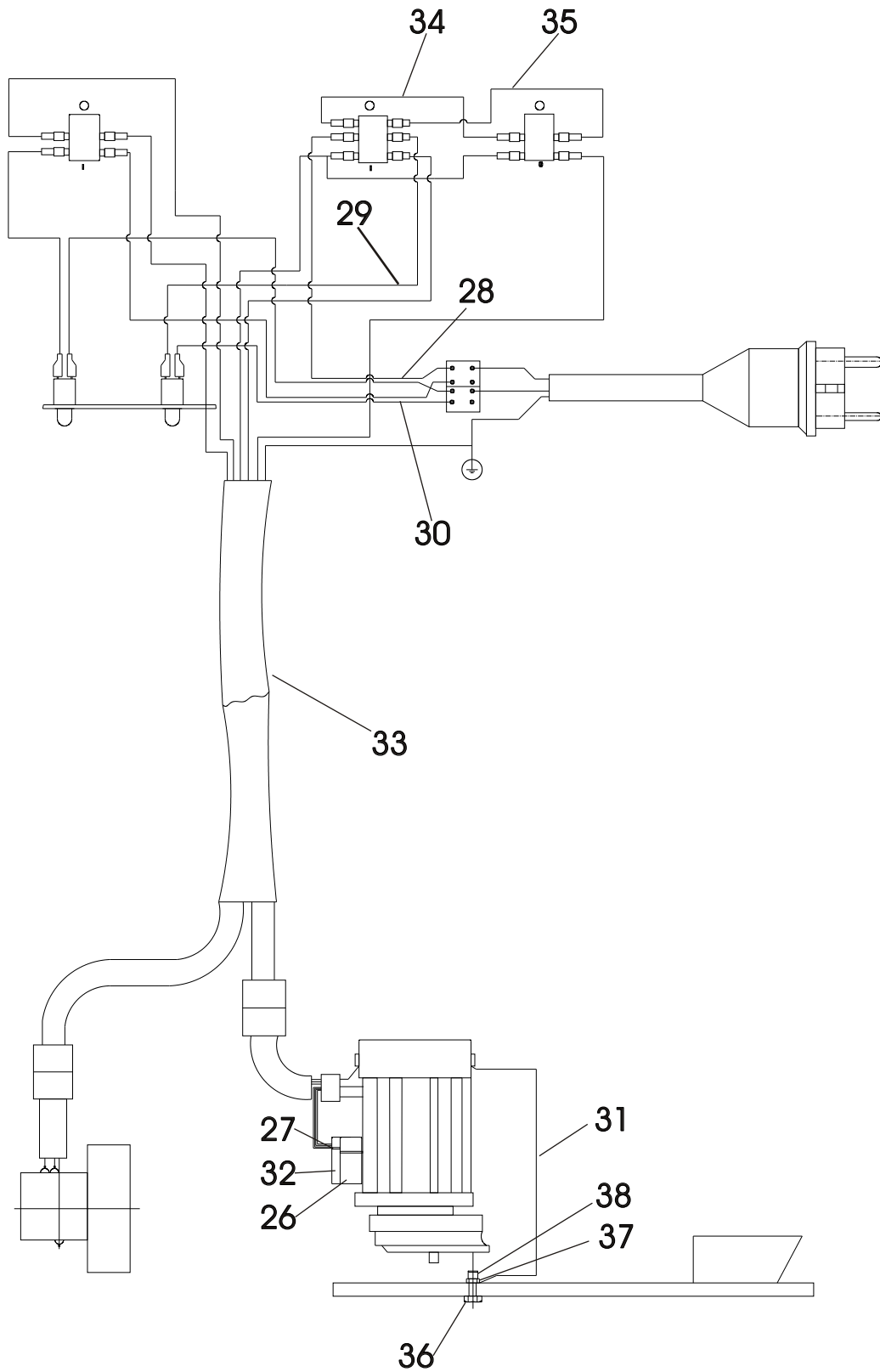

E17e ELECTRIC				
SL. NO.	PART NO.	DESCRIPTION	SIZE	QTY
26	3280051	Capacitor Assy 72 MFD(E17)		1
27	922234	Cable Tie	200	2
28	3280040	Wire Assy -X2 TO -S1		1
29	3280041	Wire Assy -X2 TO -F1		1
30	3280042	Wire Assy -F1 TO -S1		1
31	3280043	Wire Assy -X2 TO -F2		1
32	3280052	Capacitor Assy 200-250 MFD(E17)		1
33	3280046	Cable		1
34	3280044	Wire Assy -F2TO -S2		1
35	927851	Wire Assy-I		1
36	802307	Screw	M6x20	1
37	822068	Hex nut	M6	1
38	859066	Hex Nylock Nut	M6	1

## Minuteman International Made Simple Commercial Limited Warranty

Minuteman International, Inc. warrants to the original purchaser/user that the product is free from defects in workmanship and materials under normal use. Minuteman will, at its option, repair or replace without charge, parts that fail under normal use and service when operated and maintained in accordance with the applicable operation and instruction manuals. All warranty claims must be submitted through and approved by factory authorized repair stations.

This warranty does not apply to normal wear, or to items whose life is dependent on their use and care, such as belts, cords, switches, hoses, rubber parts, electrical motor components or adjustments. Parts manufactured by Minuteman are covered by and subject to the warranties and/or guarantees of their manufacturers. Please contact Minuteman for procedures in warranty claims against these manufacturers.

**Special warning to purchaser** -- Use of replacement filters and/or prefilters not manufactured by Minuteman or its designated licensees, will void all warranties expressed or implied. A potential health hazard exists without original equipment replacement.

All warranted items become the sole property of Minuteman or its original manufacturer, whichever the case may be.

Minuteman disclaims any implied warranty, including the warranty of merchantability and the warranty of fitness for a particular purpose. Minuteman assumes no responsibility for any special, incidental or consequential damages.

This limited warranty is applicable only in the U.S.A. and Canada, and is extended only to the original user/purchaser of this product. Customers outside the U.S.A. and Canada should contact their local distributor for export warranty policies. Minuteman is not responsible for costs or repairs performed by persons other than those specifically authorized by Minuteman. This warranty does not apply to damage from transportation, alterations by unauthorized persons, misuse or abuse of the equipment, use of non-compatible chemicals, or damage to property, or loss of income due to malfunctions of the product.

If a difficulty develops with this machine, you should contact the dealer from whom it was purchased.

This warranty gives you specific legal rights, and you may have other rights which vary from state to state. Some states do not allow the exclusion or limitation of special, incidental or consequential damages, or limitations on how long an implied warranty lasts, so the above exclusions and limitations may not apply to you.

**Cord Electric Group..... Three years parts, two years labor, ninety days travel (Not to exceed two hours)**

**Exceptions..... Port-A-Scrub, one year parts, six months labor**

MPV 13, one year parts

V-14, One year parts, one year labor

MPV 14 and 18, two years parts, one year labor

RapidAir blower, one year parts, one year labor

Explosion-Proof Vacuum, one year parts, one year labor

Pneumatic Vacuums, three years parts, one year labor

EX 12 and EX12H, one year parts, one year labor

TRS 14, one year parts, one year labor

**Battery Operated Group..... Three years parts, two years labor, ninety days travel**

(Not to exceed two hours)

**Exceptions..... Sweepers, one year parts, one year labor, ninety days travel**

(Not to exceed two hours)

**Internal Combustion Group.... One year parts, one year labor, ninety day travel**

(Not to exceed two hours)

**Battery Chargers ..... One year replacement**

**Replacement Parts..... Ninety days**

**Batteries..... 0-3 months replacement, 4-12 months pro-rate**

**Polypropylene Plastic Tanks... Ten years, no additional labor**

14N845 U.S. Route 20 Pingree grove, IL 60140

Phone: 800-237-3192

E-Mail: [www.minutemanintl.com](http://www.minutemanintl.com)

**A Member of the Hako Group**

3270008  
Rev.0 11/08